

# RG-710

---

OPERATING INSTRUCTIONS  
MODE D'EMPLOI  
BETRIEBSANLEITUNG  
MANUAL DE INSTRUCCIONES  
ISTRUZIONI PER L'USO

---

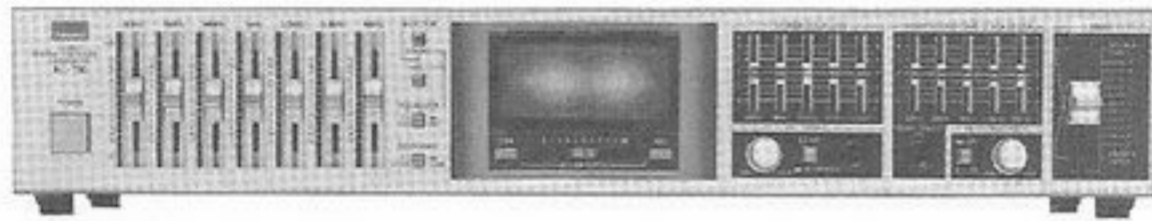

*Sansui*

We are grateful for your choice of this SANSUI high fidelity product. Before you operate it, we suggest that you read this booklet once through carefully, familiarizing yourself with the important precautions, operational pro-

cedures and every one of the product's many features. It will help to ensure that you will avoid possible damage and that the product's superb performance will be yours to enjoy for many years to come.

## Precautions

\* Bear in mind the following points.

### Power plug

When disconnecting the power cord from the power outlet, always take hold of the plug, and not the wire, and pull free. Never connect or disconnect the power plug with wet hands since you may receive an electric shock.

\* Remember to disconnect the power plug from the power outlet when you do not intend to use the unit for a prolonged period of time.

### Do not remove the case and bottom panel

Any inspections or adjustments inside the unit may lead to malfunctions and electric shocks. Do not touch any of the inside parts. SANSUI's warranty is not effective if a deterioration in the unit's performance results from remodeling inside.

### Installation precautions

Do not install the unit in any of the following locations since this may result in a deterioration in performance or malfunction:

- \* Locations exposed to direct sunlight or near objects radiating heat such as heating appliances
- \* Locations exposed to moisture or humidity
- \* Locations with poor ventilation exposed to dust and dirt
- \* Locations which are unstable and not perfectly flat or which are susceptible to vibration
- \* On top of a high power output amplifier, audio components or any other product which radiates heat.

### Do not wipe with thinners

Wipe the panels and case from time to time with a soft cloth. Using any kind of thinner, alcohol or volatile liquid will mar the surface, cause blotching on the exterior and erase the markings and should therefore be avoided.

Do not use insecticide sprays in the vicinity.

### AC Outlet

The maximum power consumption of a component connected to this power outlet is 300 watts. If a component with a higher rating is connected, it can be extremely dangerous. Always check this rating before making the connection.

**NOTE:** Depending on the laws and regulation enforced locally, models without AC outlet may be supplied to some areas. Also, depending on the sales area, the shape of the AC outlet and their capacity may differ.

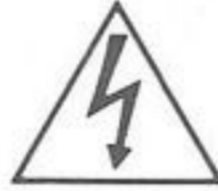
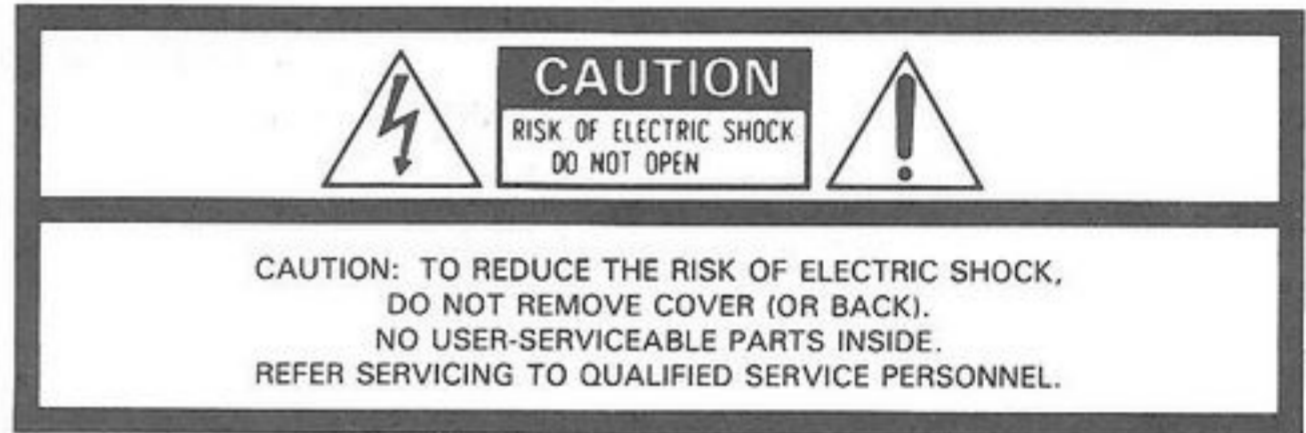

The lightning flash with arrowhead symbol, within an equilateral triangle, is intended to alert the user to the presence of uninsulated "dangerous voltage" within the product's enclosure that may be of sufficient magnitude to constitute a risk of electric shock to persons.



The exclamation point within an equilateral triangle is intended to alert the user to the presence of important operating and maintenance (servicing) instructions in the literature accompanying the appliance.

## Specifications

### Input sensitivity and impedance (1 kHz)

|                            |                   |
|----------------------------|-------------------|
| SOURCE IN, TAPE PLAY ..... | 150 mV/50 kilohms |
| MIC .....                  | 0.3 mV/10 kilohms |
| KEYBOARD.....              | 12 mV/10 kilohms  |

### Output level (1 kHz)

|                 |                   |
|-----------------|-------------------|
| TAPE REC.....   | 150 mV/47 kilohms |
| MIXING OUT..... | 150 mV/47 kilohms |

### Total harmonic distortion (1 kHz, 2V)

|                |       |
|----------------|-------|
| SOURCE IN..... | 0.05% |
|----------------|-------|

### Frequency response (150 mV)

|                |                                 |
|----------------|---------------------------------|
| SOURCE IN..... | 20 Hz ~ 20 kHz,<br>+1 dB, -2 dB |
|----------------|---------------------------------|

### Signal to noise ratio (Short-circuit, A-network)

|                |       |
|----------------|-------|
| SOURCE IN..... | 75 dB |
|----------------|-------|

### Channel separation (1 kHz)

|                |       |
|----------------|-------|
| SOURCE IN..... | 60 dB |
|----------------|-------|

|                             |   |
|-----------------------------|---|
| Reverb time.....            | 0 ~ 3 sec.  |
| Delay time.....             | 20 msec.  |
| Power requirements.....     | 120/220/240V<br>(50/60 Hz)                                      |
| For U.S.A. and Canada ..... | 120 V (60 Hz)   |
| Power consumption.....      | 15W   |
| Dimensions .....            | 430 mm (16-15/16") W<br>78 mm (3-1/8") H<br>223 mm (8-13/16") D |
| Weight.....                 | 2.8 kg (6.2 lbs) net<br>3.5 kg (7.7 lbs) packed                 |

- \* Design and specifications subject to change without notice for improvements.
- \* In order to simplify the explanation illustrations may sometimes differ from the originals.

# Connections

ENGLISH

\* Mains plug may vary to some extent depending on sales area, local laws and regulations.

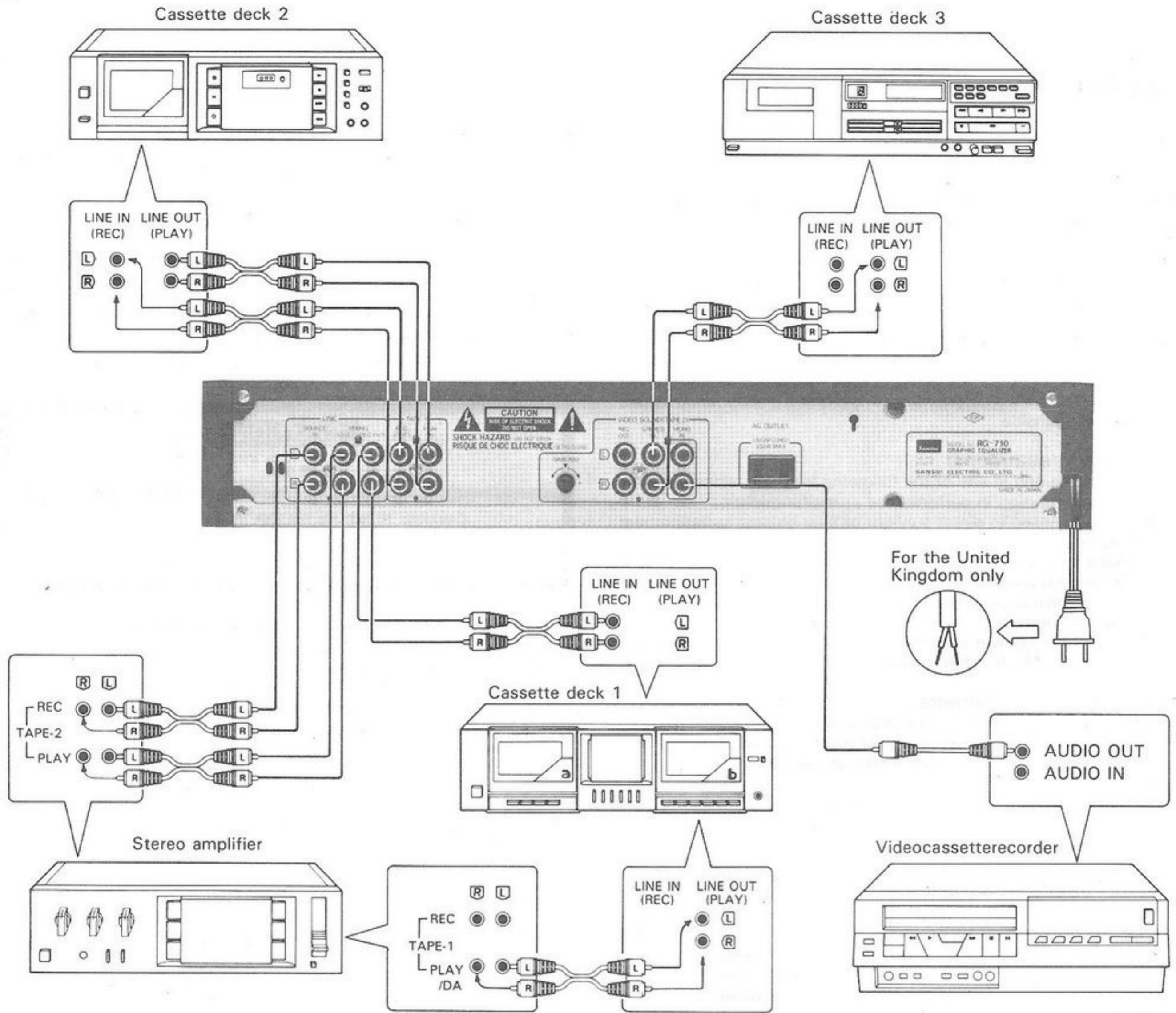

## For the United Kingdom only

### Important

The wires in this mains lead are coloured in accordance with the following code:

- Blue:** Neutral
- Brown:** Live

If the colours of the wires in the mains lead of this equipment should not correspond to the coloured markings identifying the terminals in your plug, proceed as follows:

The wire which is coloured **blue** must be connected to the terminal which is marked with the letter 'N' or coloured black.

The wire which is coloured **brown** must be connected to the terminal which is marked with the letter 'L' or coloured red.

Ensure that your equipment is connected correctly. If you are in any doubt, consult a qualified electrician.

For equipment purchased outside the U.K. with a "EUROPEAN" two-pin mains plug, the plug should be removed and connections made in accordance with the above instructions. Ensure also that the equipment is properly adjusted to 240 volts operation. If you are in any doubt, consult a qualified electrician, or our Service Agent in the U.K.

AC outlet on the rear panel accepts AC power plug "BULGIN P.772" or equivalent.

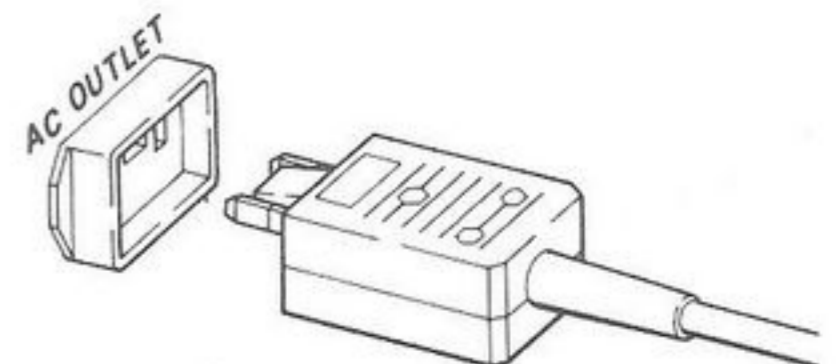

## Connection Precautions

- \* When connecting, either disconnect the power plug from the power outlet or turn off the unit's power using the POWER switch.
- \* Before connecting, read through the Operating Instructions of the other audio components which will be connected to this unit.
- \* Check the left and right channels and connect properly (L to L and R to R).
- \* Insert the plugs securely. Improper connection can lead to the generation of noise.

## Amplifier or Receiver Connections

Connect the TAPE-2 REC terminals on the amplifier or receiver to the SOURCE IN terminals on the RG-710 and the TAPE-2 PLAY terminals on the amplifier or receiver to the MIXING OUT terminals on the RG-710 using the accessory pin plug cords.

## Connections when using a SANSUI cassette deck with Compu-Selector, or single cassette deck

Connect as shown for cassette deck-1 in the connection diagram. Connect this unit's MIXING REC OUT terminals to the LINE IN (REC) terminals of a cassette deck, and connect the cassette deck's LINE OUT (PLAY) terminals to the TAPE-1 PLAY terminals of the amplifier.

## Connecting a Second Cassette Deck

Connect as shown for cassette deck-2 in the connection diagram. Connect this unit's TAPE-1 REC (OUT) terminals to the LINE IN (REC) terminals of the cassette deck, and connect the cassette deck's LINE OUT (PLAY) terminals to this unit's TAPE-1 PLAY (IN) terminals.

## Connecting a Videocassette recorder

When the unit is connected to the audio output/input terminals of a videocassette recorder, you can play back and record the audio portion of the video cassette tape while adding various modifications and sound mixing.

When using a videocassette recorder with monaural sound, perform connections in the following way:

**Playback:** Connect only the videocassette recorder's AUDIO OUT terminal to one of this unit's PLAY IN (MONO) terminals.

**Recording:** Use a Y-type pinplug cord to connect the videocassette recorder's AUDIO IN terminal to this unit's REC OUT terminals.

## Precautions regarding the use of TAPE-2/VIDEO SOUND terminals

When performing recording or playback with the videocassette recorder or cassette deck connected to the TAPE-2/VIDEO SOUND terminals, connect the respective components as shown in the appropriate illustrations. The playback terminals and recording terminals cannot be used when simultaneously connected. When performing playback, connect only the playback terminals, and when performing recording, connect only the recording terminals.

### Connections for playback

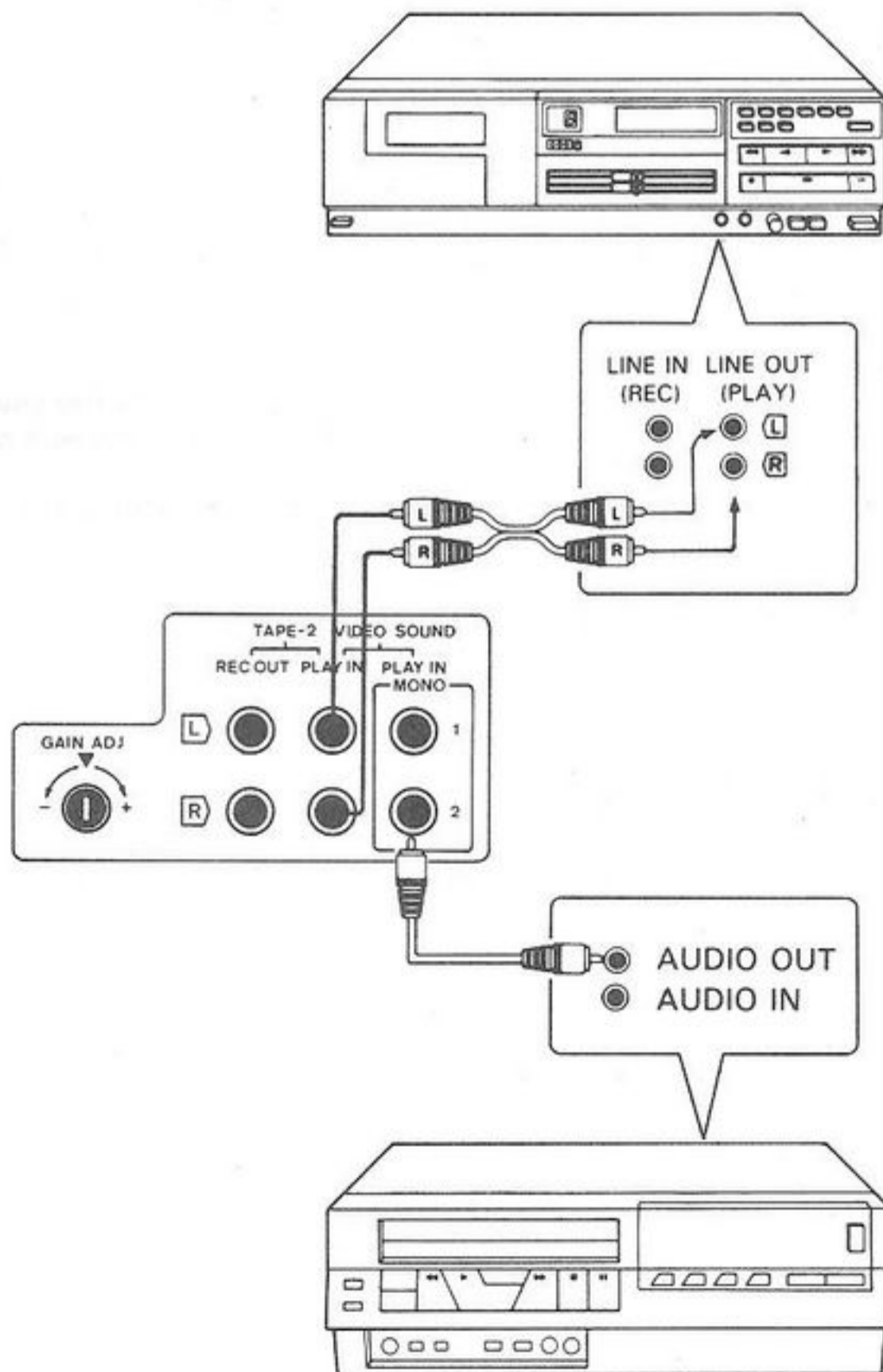

### Connections for recording

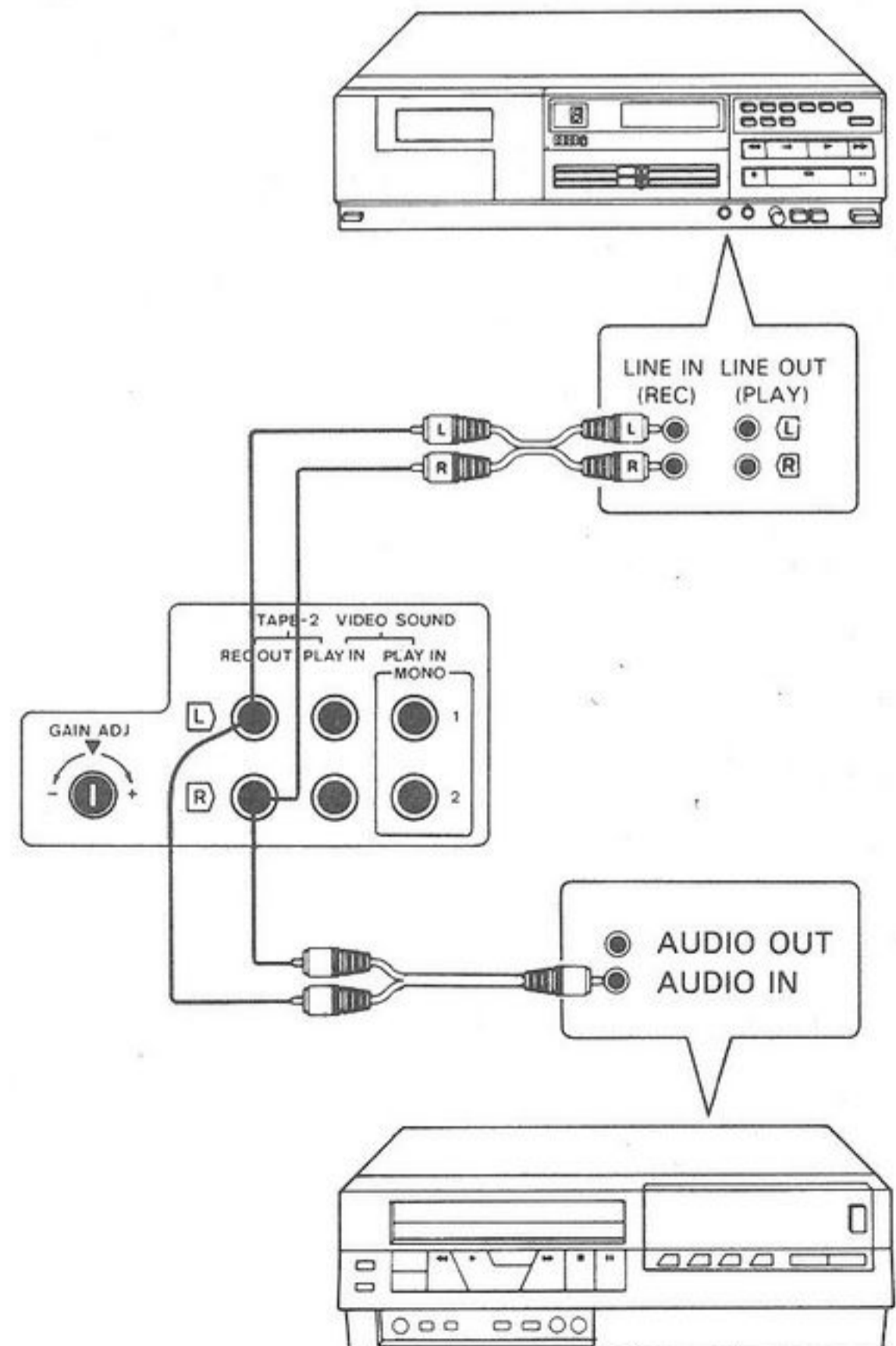

# Panel information

\* The photos and illustrations show a unit with a silver panel.

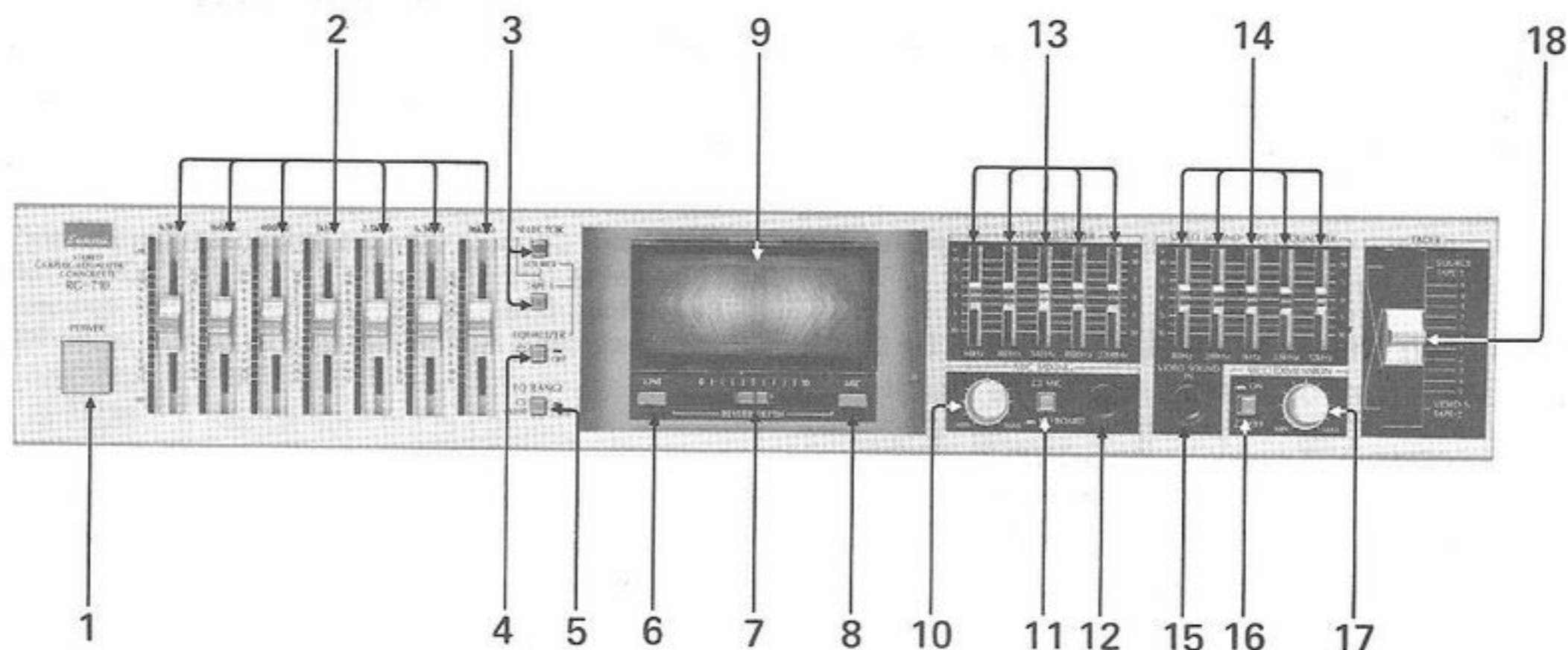

## 1 POWER Switch

Power is supplied to the unit when this switch is pressed and the sound display lights. When pressed again, the switch is released and the power is switched off.

## 2 Equalizer Controls

These controls allow you to add tonal coloring (equalization) to the sounds of program sources selected with the SELECTOR switches. When the EQUALIZER switch is at the "ON ()" position, the level near the frequency indicated above each of the controls can be continuously controlled across a +12 dB to -12 dB range.

The level is made flat at the center clickstop "0" position of the controls. When a control is slid upward from this position, the level for both channels is increased simultaneously centering on that frequency; when slid downward, the level is reduced. Adjust the level of each of the frequencies according to your personal preference.

- The range of levels which can be controlled is selected with the EQ RANGE switch, and can be set to either the +12 dB ~ -12 dB, or +6 dB ~ -6 dB positions.
- When the EQUALIZER switch is at the "OFF ()" position, the sound quality cannot be compensated for even by operating the controls.

## 3 SELECTOR Switches

These switches are used to select program sources for listening.

**SOURCE:** Press this switch when listening to programs from the tuner or turntable connected to your amplifier.

**TAPE-1:** Press this switch when listening to playback of the cassette deck connected to the rear-panel TAPE-1 terminals.

## 4 EQUALIZER Switch

Set this switch to ON () and adjust the equalizer controls when you wish to add equalization effects to the sounds of SOURCE or TAPE-1 programs (selected with the SELECTOR switches).

When this switch is set to OFF () , frequency characteristics will be "flat" (normal), regardless of the position of the equalizer controls.

## 5 EQ RANGE Switch

This switch is used to select the range in which adjustment can be performed with the equalizer controls. When set to the  $\pm 12$  dB position, the range of each equalizer control is broad, allowing for wider adjustments. When set to the  $\pm 6$  dB position, the range of each control is cut in half, allowing more delicate adjustments to be made.

## 6 LINE Reverb Switch

By depressing this switch, reverberation effects can be added to sounds of broadcasts, records, or tapes. When you do not wish to add reverberation effects, press the switch again and set to the released position.

## 7 REVERB DEPTH Control

This is used to control the amount of reverberation effect added to program sounds. By sliding the control to the right, reverberation effects are increased. Effects are decreased by sliding the control to the left. The pattern shown on the sound display changes in response to the amount of reverberation effects added.

## 8 MIC Reverb Switch

When this switch is pressed, reverberation effects are added to sounds from the microphone or keyboard instrument connected to the MIC jack. When you do not wish to add reverberation effects, press the switch again and set to the released position.

## 9 Sound Display

The pattern on this display changes at the same time as the depth of the echo effect is varied by the REVERB DEPTH control, and so it is possible to monitor this effect visually.

The illumination also changes in accordance with the strength and frequency components of the input signals.

## 10 MIC MIXING Control

This knob controls the sound volume for microphone or keyboard instrument connected to the MIC jack. When rotated to the right, the sound volume level is increased.

## 11 MIC MIXING Switch

When connecting a microphone to the MIC jack, set this switch to MIC () . When connecting a keyboard or guitar with high output-level, set this switch to KEYBOARD () .

## 12 MIC Jack

When using a microphone, guitar, or keyboard instrument, its output plug is inserted in this jack. The sound from the connected instrument or microphone will be situated evenly between the right and left speakers.

\* When not using the microphone or instrument, be sure to disconnect its plug from the jack.

### 13 REVERB EQUALIZER

In addition to varying the amount of reverberation effect, you can use these controls to change the frequency response of the reverberation sound as well, thus adding a wealth of new possibilities for creative sound mixing.

The reverb level of each of the frequency ranges indicated above the controls can be varied within a range of +10 ~ -10 dB. When a control is in its center click position, the corresponding frequency response will be flat (normal). When a control is moved upward, that frequency range will be emphasized, and when the control is moved downward, that frequency range will be deemphasized.

### 14 VIDEO SOUND/TAPE-2 EQUALIZER Controls

These controls are used for adding tonal equalization to the sounds from a videocassette recorder or cassette deck-3.

The level near the frequency indicated above the controls can be continuously controlled across a +10 dB to -10 dB range using these controls. The level is made flat at the center clickstop position. When a control is slid upward from this position, the level is increased centering on that frequency; when it is slid downward, the level is reduced.

- When sound quality compensation is not required, set all the controls to their center clickstop position.

### 15 VIDEO SOUND IN Jack

This jack is used when connecting the audio output from a video cassette or tape deck by means of a stereo phono plug. Since this jack has the same connection function as the rear-panel VIDEO SOUND STEREO IN terminals, you can use both terminals and jack to simultaneously connect two different program sources.

### 16 MULTIDIMENSION Switch

"MULTIDIMENSION" is a function which allows you to add increased breadth and concert-hall realism to the sound from the right and left speakers. When using this function, press the switch to ON (■). When not using the function, release to OFF (□).

### 17 MULTIDIMENSION Control

When the right-side switch is set to ON (■), rotating this control clockwise will add increased breadth to the sound from your speakers, expanding their sound image outside the speakers themselves. Setting the control at "MAX" gives the greatest degree of effect.

### 18 FADER Control

By using this control, you can simultaneously control the sound volume from both SOURCE or TAPE-1 (cassette deck-2) component, and also VIDEO SOUND or TAPE-2 (cassette deck-3) component. When set to the center position, the two sounds will be output in equal proportions; when the control is moved upward, the sound from VIDEO SOUND or TAPE-2 will decrease, while sounds from SOURCE or TAPE-1 are increased. In contrast, when the control is moved downward from the center position, sounds from SOURCE or TAPE-1 will be decreased while sounds from VIDEO SOUND or TAPE-2 are increased.

- \* The rear-panel GAIN ADJ control should be adjusted so that, when the FADER control is set to its center position, the sound levels from SOURCE or TAPE-1 and those from VIDEO SOUND or TAPE-2 are equal.

## Operating procedures

### Operation of amplifier or receiver connected

Set the input selector or tape monitor switch to "ON" corresponding to the tape terminals to which connection has been made on the RG-710 and corresponding to the amplifier or receiver used.

- \* Set the switch to "SOURCE" when the amplifier or receiver comes with a rec out selector switch.

### Reception and record play

1. Press the POWER switch to switch on the unit's power.
2. Press the unit's SOURCE switch of the SELECTOR switches.
3. Set the volume control on the amplifier or receiver to the usual listening position.
4. Select the program source using the input selector switch on the amplifier or receiver, tune in the broadcast station or play the record, and adjust the volume using the amplifier's VOLUME control.

### Tape playback

1. When only 1 cassette deck is connected, or when playing back cassette deck-1: Press the SOURCE SELECTOR switch, and slide the FADER control upward.

**Playback on cassette deck-2:** Press the TAPE-1 SELECTOR switch, and slide the FADER control upward.

**Playback on cassette deck-3 or video cassette recorder:** Slide the FADER control downward.

2. Set the tape deck to the playback mode, and use the amplifier's volume control to adjust the sound volume.

- \* The FADER control can be used to switch from record or TAPE-1 sounds to TAPE-2 or video sounds by smoothly fading the respective sounds out and in without a sharp break between the two. In addition, the control can be used as a mixing control for two different sounds.

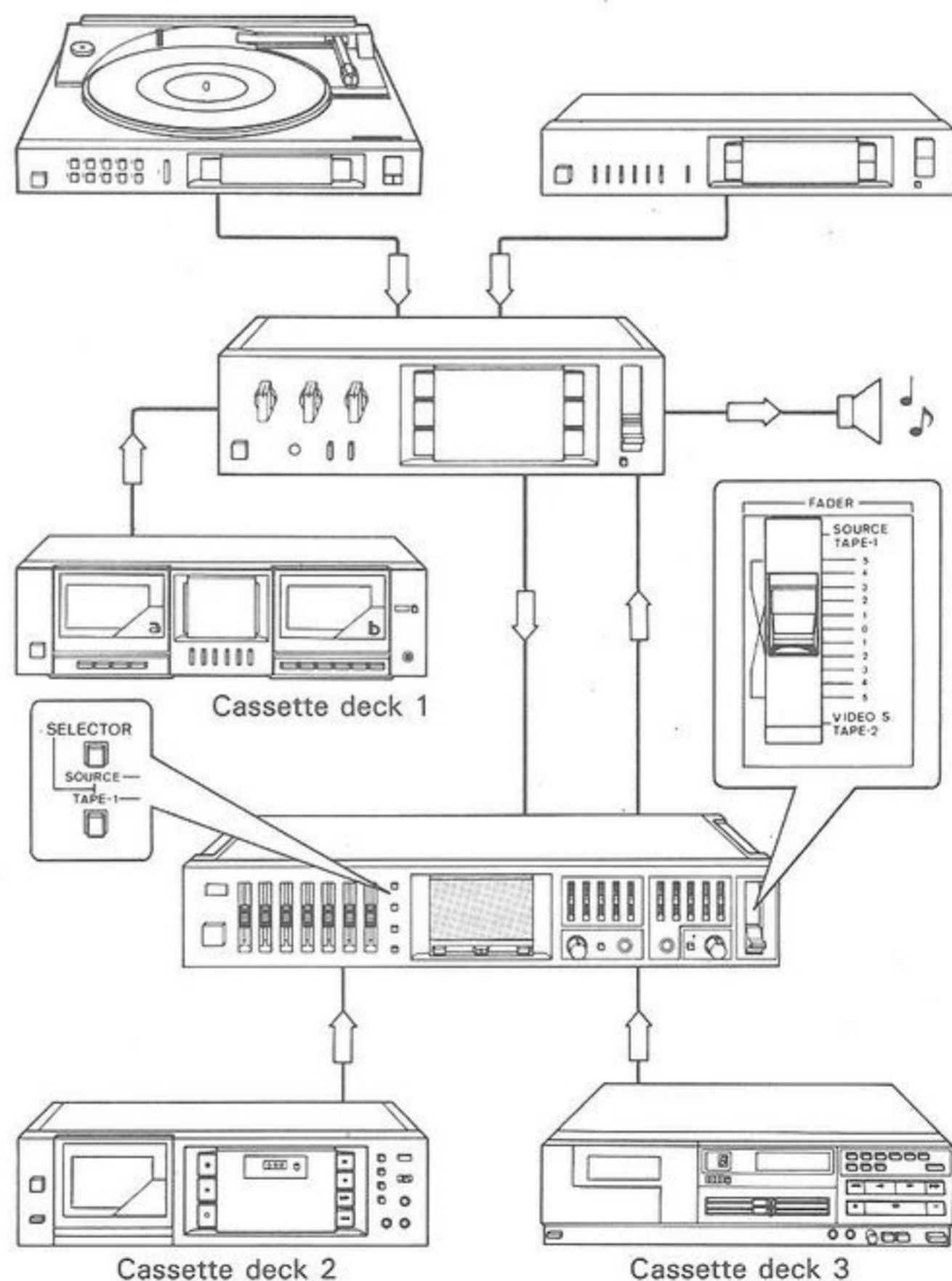

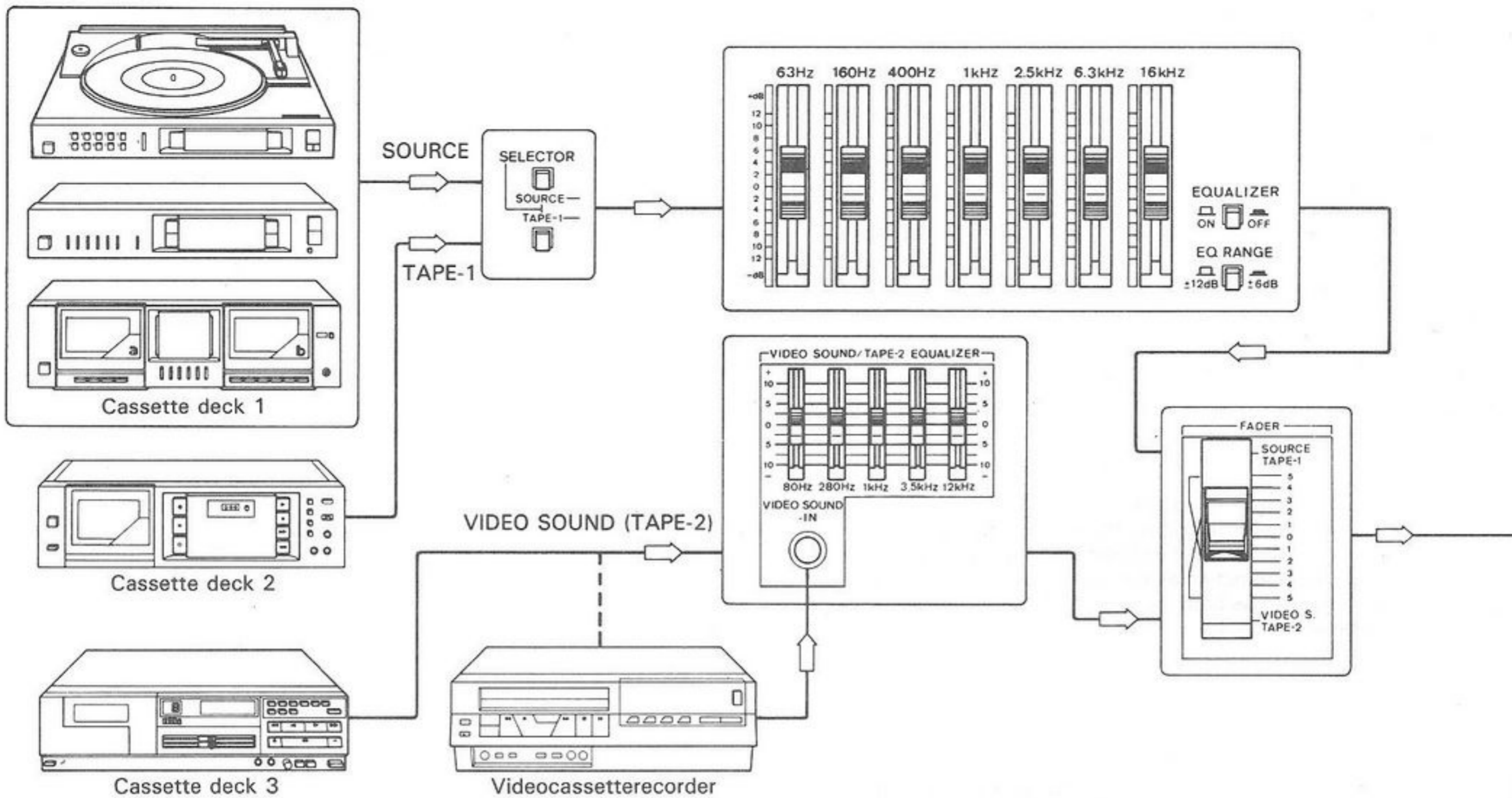

Perform the following procedures when adding sound equalization and reverberation effects, or when performing sound mixing of program source and microphone or keyboard instrument

### Playing a program source with added equalizer effects

This unit can be used to achieve subtle frequency compensation which is not possible using the tone controls or filters of amplifier.

You can not only compensate for fluctuations in the frequency response produced by the shape of the listening room and cut out the undesirable frequencies but also color the sound of the program source as desired. In other words, this unit gives you complete control over the sound.

1. Play back the selected program source.
2. Set the EQUALIZER switch to the ON position.
3. Adjust the volume of sound with the amplifier's volume control.
4. Play the music and adjust the equalizer controls to achieve equalizing. When they are slid above the center "0 dB" position, the level near the indicated frequency is increased; when they are slid below the position, the level is reduced.
5. The equalizing effect can be checked momentarily by setting the EQUALIZER switch to the OFF and ON positions.

\* When the EQUALIZER switch is at the OFF position, the sound quality cannot be compensated for even when the equalizer controls are operated.

\* When performing tone equalization of sounds from video cassette recorder or cassette deck-3, slide the FADER control downward and use the special 5-band equalizer.

### Sound mixing of program source with microphone or keyboard

1. Connect the plug from microphone or keyboard instrument to the MIC jack.
2. Set the MIC MIXING switch to MIC (  ) when using a microphone, and set to KEYBOARD (  ) when using a keyboard or guitar.
3. Rotate the MIC MIXING control to adjust the sound volume balance with the program source.
  - When using the microphone and also listening to the sound through the speakers, take care with the positioning of the microphone and speakers and also with the direction of the microphone as "howl" may occur.
  - Use a microphone with an impedance of 200 ohms to 10 kilohms; it should be a dynamic or electret type. If the microphone's impedance is too low, the sensitivity may be insufficient.

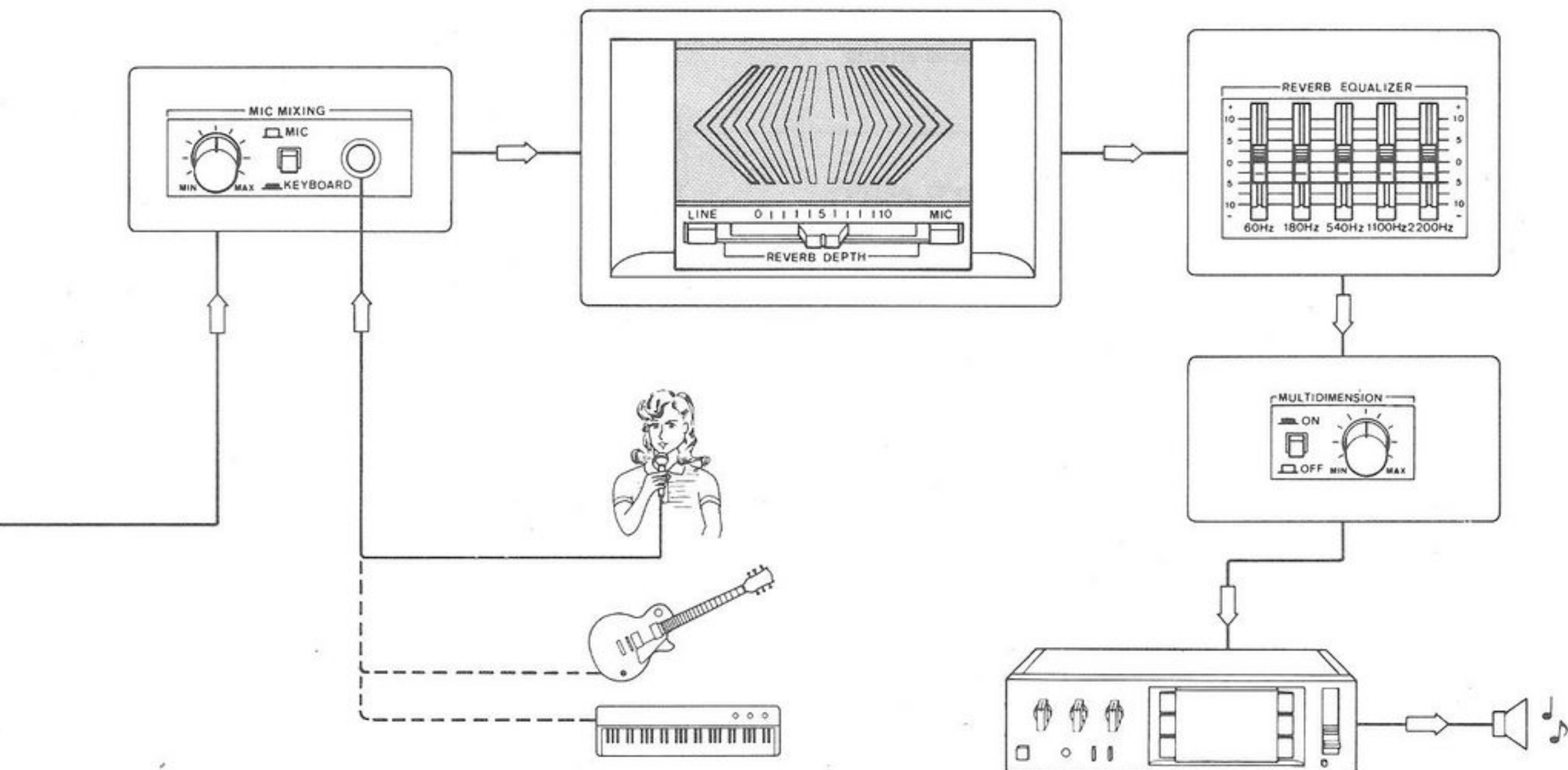

### Playback with reverb effects added

Sounds from cassette tape, microphone, and all other program sources can be modified to achieve various sound and tonal changes by adding the three special effects reverberation, reverberation equalization, and MULTIDIMENSION.

1. To add reverberation effects to tape or record sounds, press the LINE reverb switch. To add reverberation effects to microphone or keyboard sounds, press the MIC reverb switch. When both switches are pressed, reverberation effects will be added to the sounds from both sources.
2. While listening to the playback sound, slide the REVERB DEPTH control to vary the amount of reverberation effect added. The sound display pattern will change in response to the added effect.
3. By adjusting the position of the REVERB EQUALIZER controls, the reverberation effect of specific frequency ranges can be selectively increased or decreased. When the reverb effect in the low sound ranges is increased, a soft sound effect is produced, while increasing the reverb effect in the high ranges will produce a more metallic sound.
4. To add MULTIDIMENSION effects, set the MULTIDIMENSION switch to ON, and adjust the control to achieve the desired effect. The breadth of sound is emphasized as the control is rotated clockwise.



## Recording with special effects added

Mixed sounds, or sounds with equalization and/or reverberation effects added can be recorded on a cassette deck connected to the unit.

1. Select the program source you wish to record, and set to playback.
2. When performing mixing, connect a microphone or keyboard instrument.
3. Operate the various switches and controls to added special effects as desired.
4. Operate the cassette deck to begin recording.

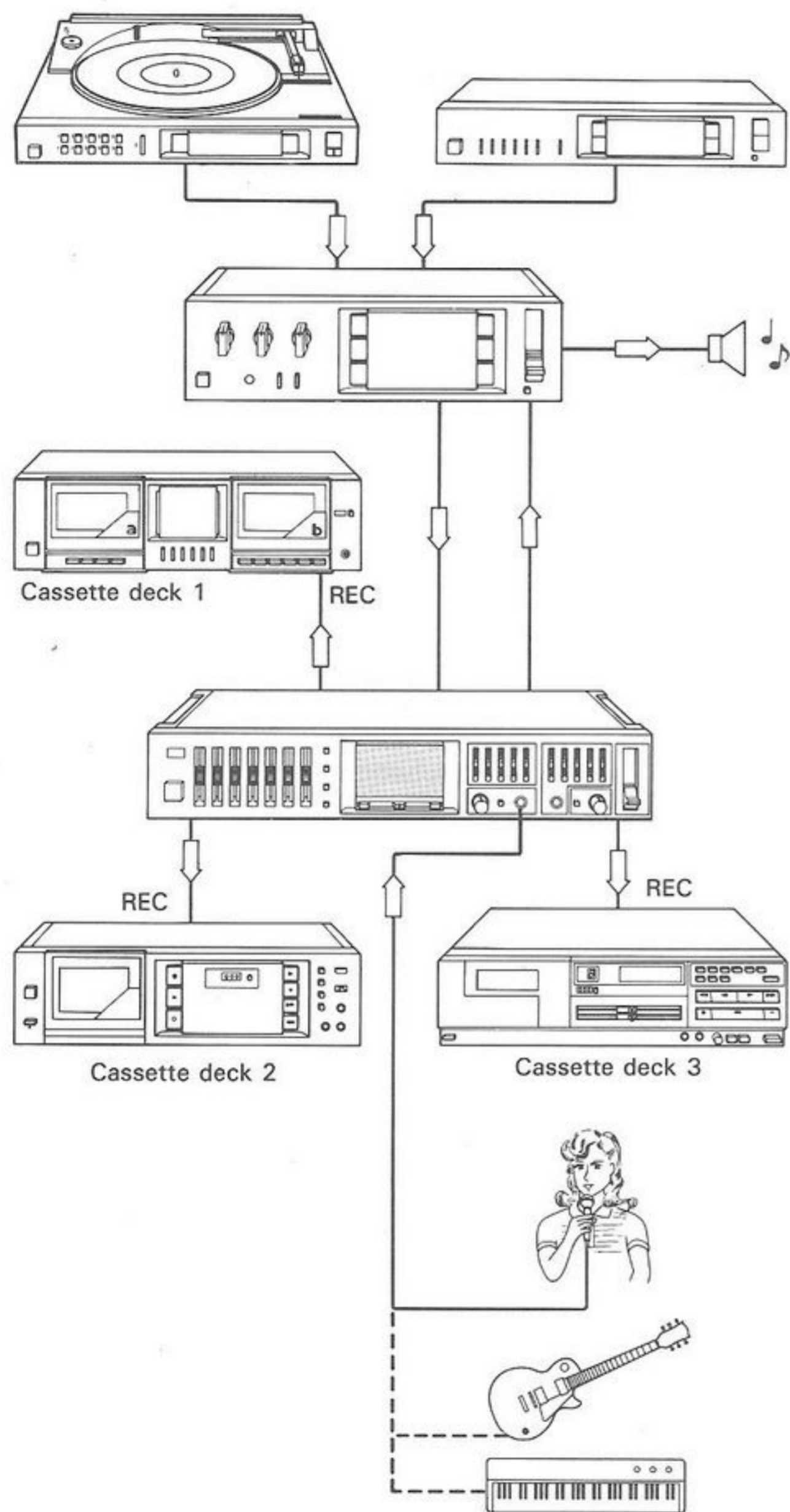

- When two cassette decks are connected to the unit, mixing or other special effects can be added to the sounds from the first deck, and the resulting sounds recorded on the second deck.

### When 2 cassette decks are used.

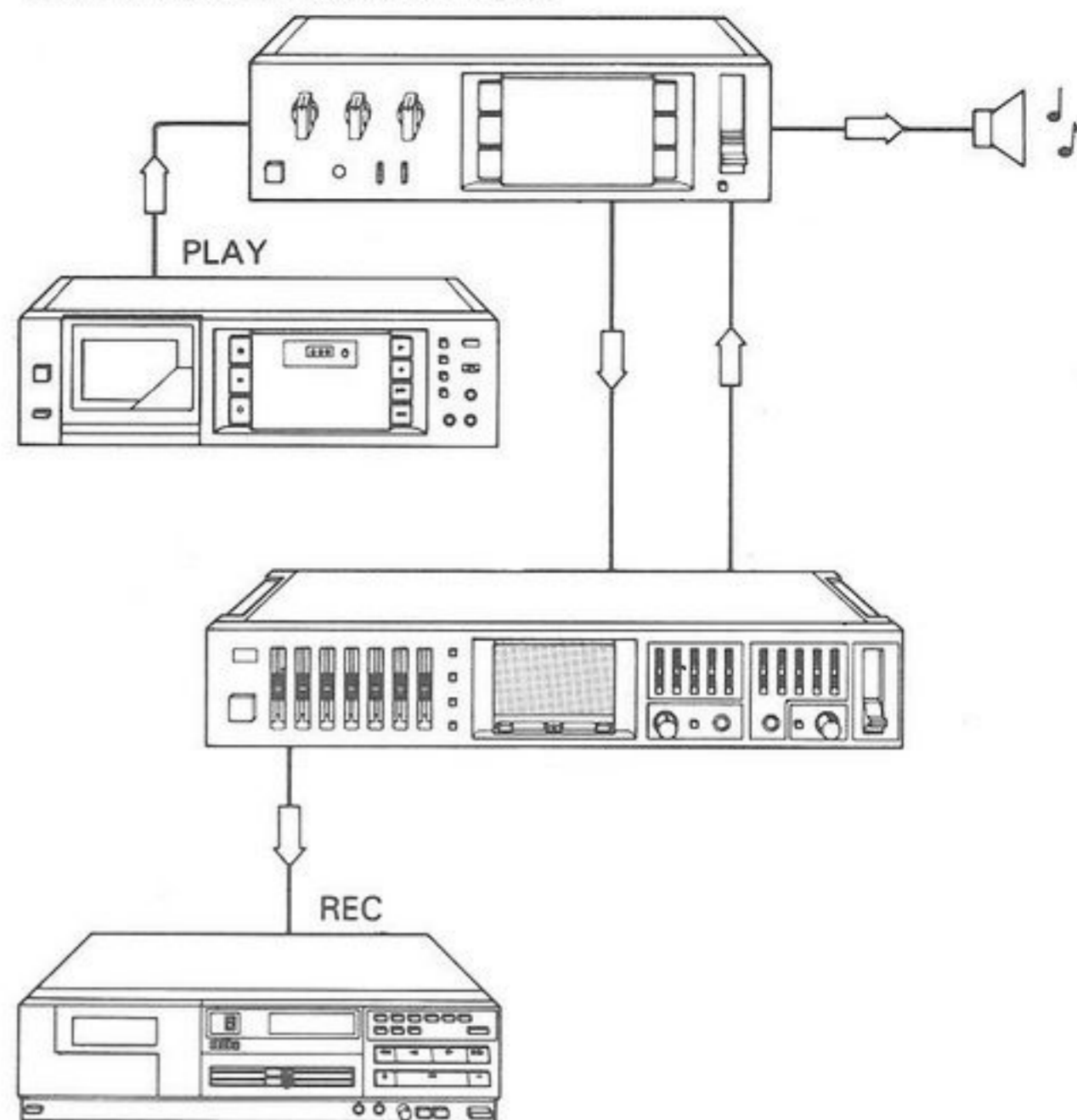

- When using a SANSUI double cassette deck (D-99MW, D-99CW), mixing or other special effects can be added to the sounds from deck "a", and the resulting sounds recorded on deck "b". In this case, do not press the dubbing switch, but merely operate deck "a" for playback and deck "b" for recording.

### When a double-cassette deck is used.

